

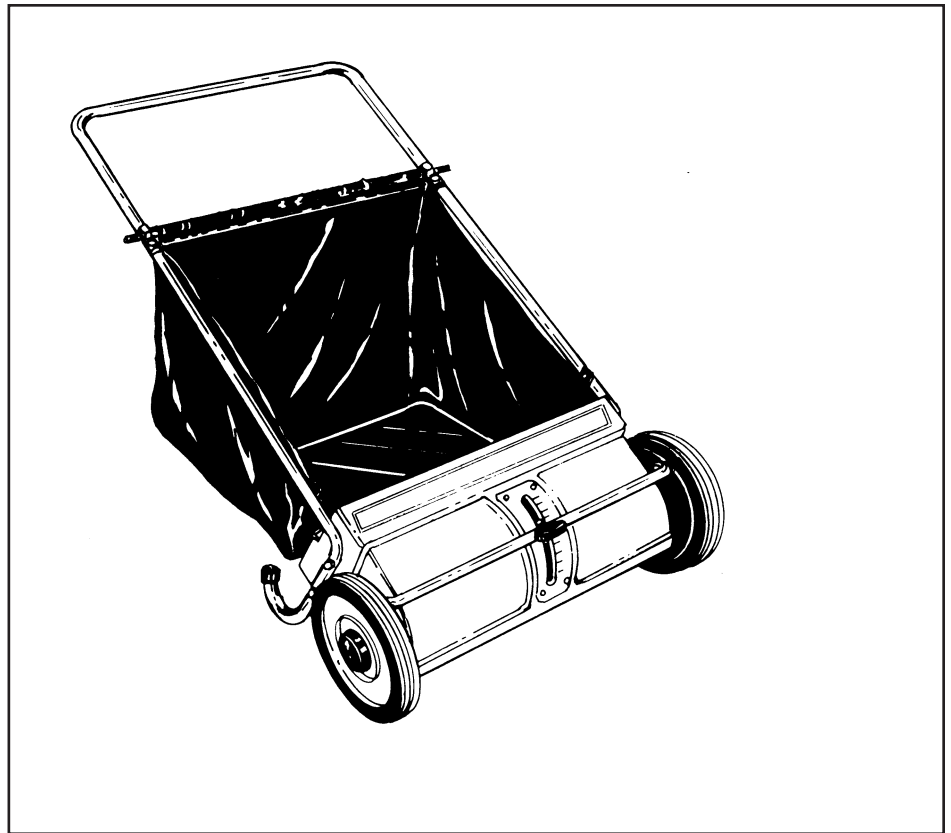

OWNERS MANUAL

**Model No.
45-02181**



26" LEAF/LAWNSWEEPER

CAUTION:
Read Rules for
Safe Operation
and Instructions
Carefully

- **Safety**
- **Assembly**
- **Operating**
- **Maintenance**
- **Repair Parts**

SpeedEPart *the fastest way to purchase parts* www.speedepart.com

SAFETY RULES

Remember, any equipment can cause injury if operated improperly or if the user does not understand how to operate the equipment. Exercise caution at all times when using this equipment.



LOOK FOR THIS SYMBOL TO POINT OUT IMPORTANT SAFETY PRECAUTIONS. IT MEANS — ATTENTION! BECOME ALERT! YOUR SAFETY IS INVOLVED.



CAUTION: VEHICLE BRAKING AND STABILITY MAY BE AFFECTED WITH THE ADDITION OF AN ACCESSORY OR AN ATTACHMENT. BE AWARE OF CHANGING CONDITIONS ON SLOPES.

- Do not allow anyone to operate the sweeper without proper instructions.
- Do not permit children to operate sweeper.
- Eye protection should be worn while operating sweeper.
- Do not push or tow sweeper too close to a fire.
- Do not attempt to remove wire or string wrapped around brush while brush is rotating.
- Operate sweeper at reduced speed on rough terrain, in ditches and on hillsides to prevent tipping and loss of control. Stay alert for holes or other hidden hazards.
- This sweeper is not meant for street or highway use. Watch for traffic when sweeping near roadways.
- Keep all nuts, bolts and screws tight to be sure equipment is in safe working condition.
- Sweeper should be stopped and inspected for damage after striking a foreign object and damage should be repaired before operating the equipment.
- Follow maintenance instructions as outlined in this manual.

CARTON CONTENTS

1. Sweeper Housing Assembly
2. Hopper Bag
3. Upper Handle
4. Lower Handle Leg Stand (2)
5. Short Bag Rod
6. Long Bag Rod

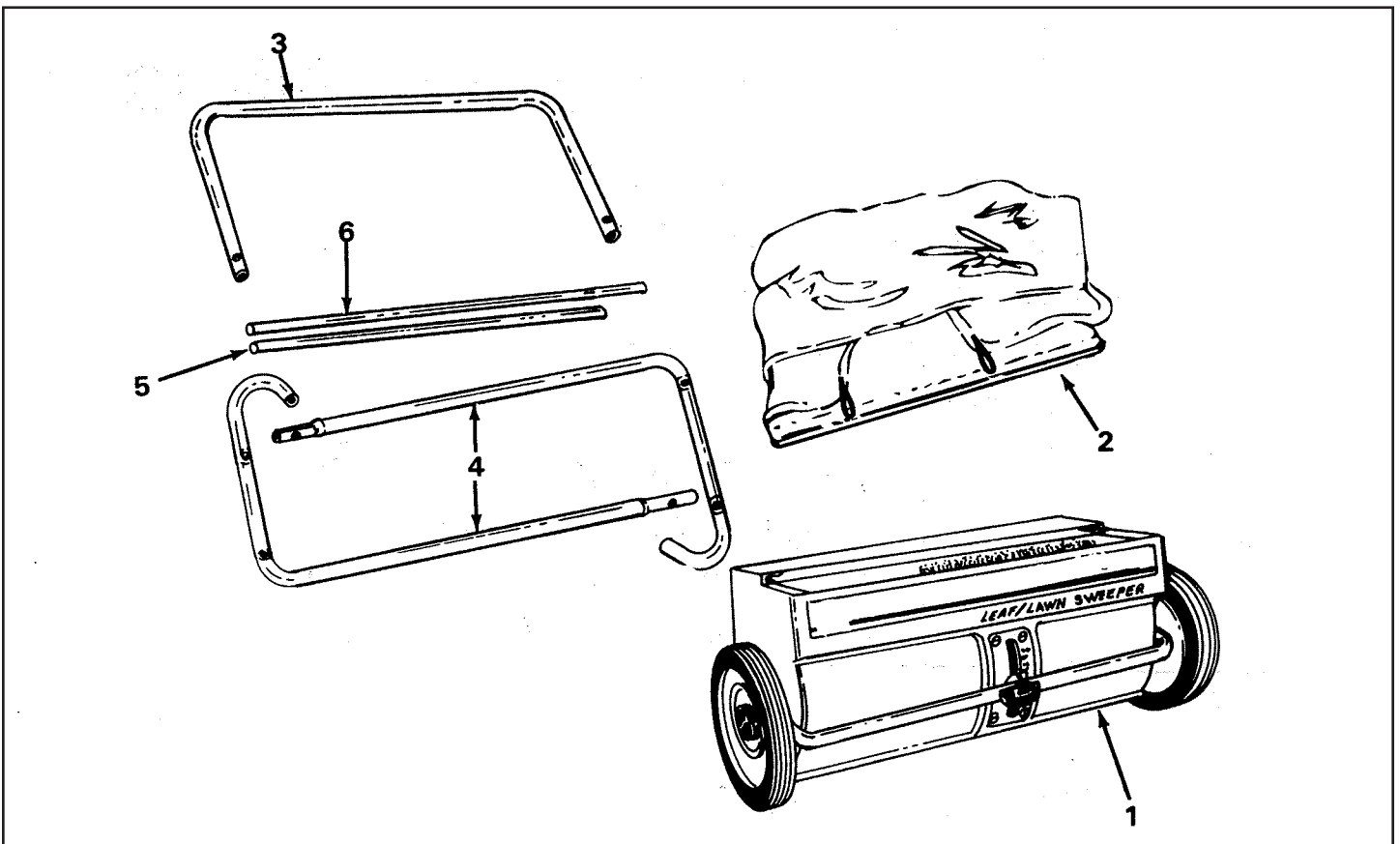

HARDWARE PACK (NOT SHOWN FULL SIZE)

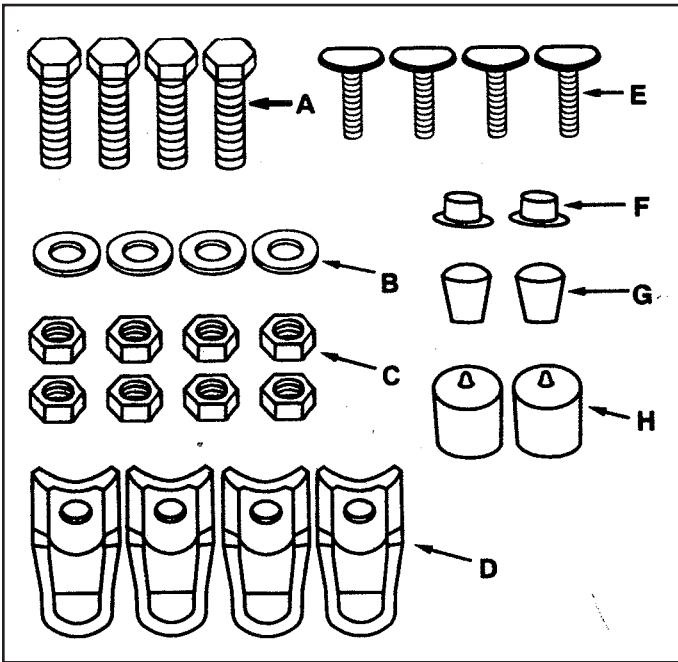

Ref. No.	Description	Qty.
A	Hex Bolt, 1/4-20 x 1-1/4"	4
B	Flat Washers 1/4" I.D.	4
C	Hex Lock Nuts 1/4-20	8
D	Bag Rod Clips	4
E	Curved Head Bolts 1/4-20 x 1"	4
F	Palmnut 1/4"	2
G	Plastic Caps (for bag rods)	2
H	Plastic Caps (for leg stands)	2

ASSEMBLY INSTRUCTIONS

TOOLS REQUIRED FOR ASSEMBLY

- (1) Phillips Screwdriver
- (1) Adjustable Wrench
- (1) 7/16" Open End or Box Wrench

1. Assemble the two Handle Leg Stand Tubes to the Sweeper Housing, using two hex bolts 1/4-20 x 1-1/4" long, flat washers and 1/4-20 hex lock nuts, per handle. See figure 1. Only hand tighten at this time.

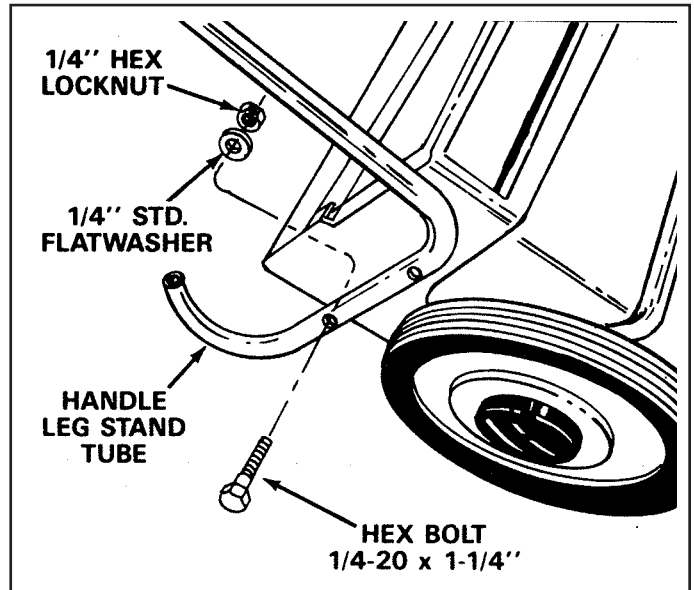

FIGURE 1

2. Assemble the Upper Handle Tube over the Handle Leg Stand Tubes. See figure 2. Align holes in handle and assemble the Bag Rod Clips to the handle as shown and fasten with curved head bolts and hex lock nuts.

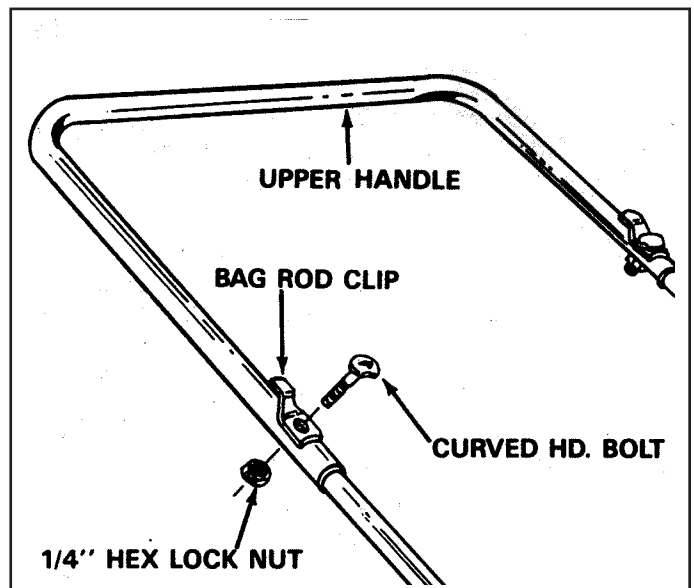

FIGURE 2

- Now tighten the four bolts from step 1.
- Assemble a bag rod clip to the inside of each lower handle tube using a curved head bolt secured down against the clip using a 1/4" lock nut. The open end of the clips should face towards the sweeper housing. See figure 3.

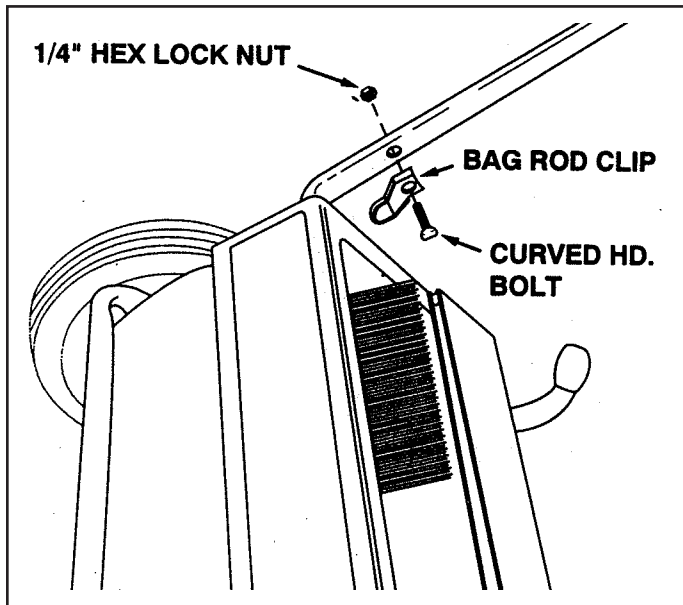

FIGURE 3

- Slide the long bag rod (28-1/2" long) through the stitched bag flap on the top of the hopper bag as shown in figure 4.
- Slide the short bag rod (25-1/2" long) through the stitched bag flap on the bottom of the hopper bag as shown in figure 4.

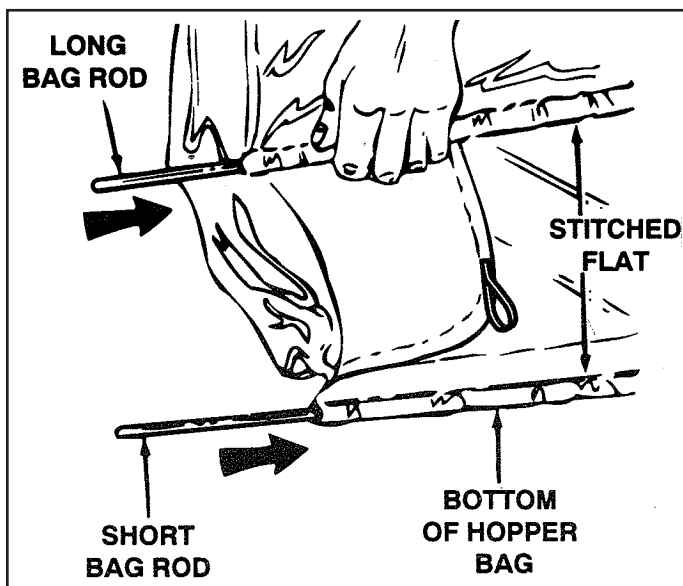

FIGURE 4

- Assemble the two plastic rod caps to the rod ends of the bottom bag rod. Assemble two Palnuts to the ends of the top bag rod. See figure 5.

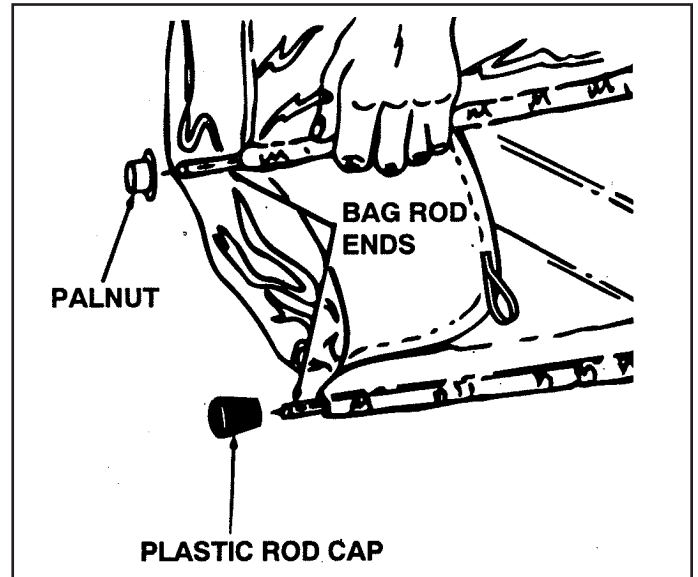

FIGURE 5

- Assemble the two plastic caps 3/4" x 7/8" onto the ends of the leg stands as shown in figure 6.

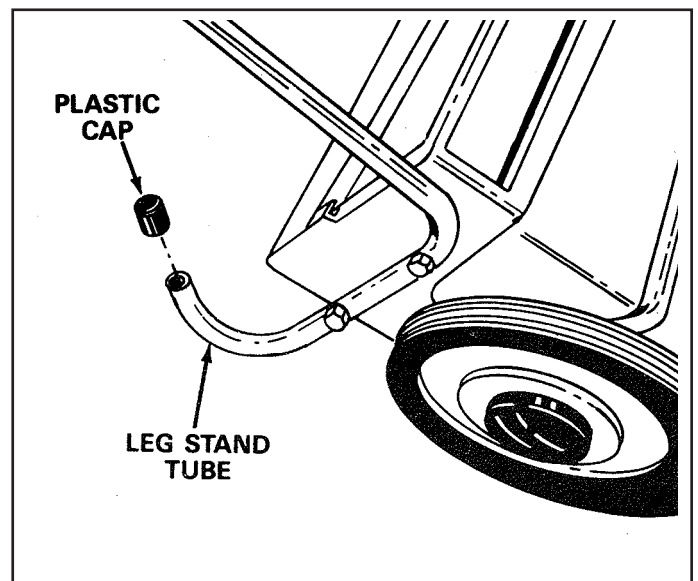

FIGURE 6

9. Place the upper hopper bag and bag rod into the bag rod clips on the hopper handle. See figure 7.

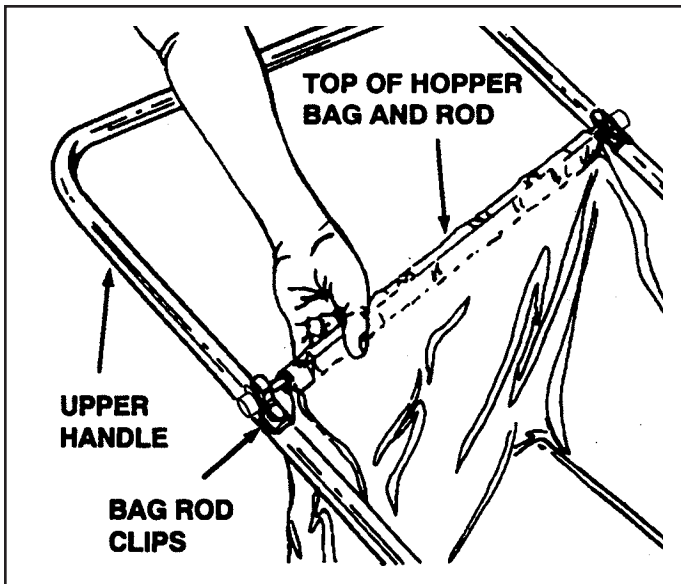

FIGURE 7

10. Place the lower hopper bag and bag rod into the opening on the sweeper housing. See figure 8.

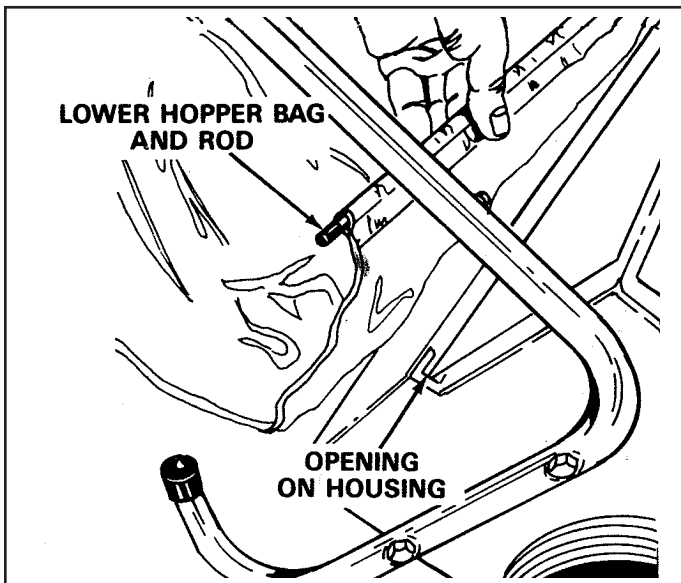

FIGURE 8

11. Hook the elastic straps on the bag flaps under the bag rod clips on the lower handle tubes as shown in figure 9.

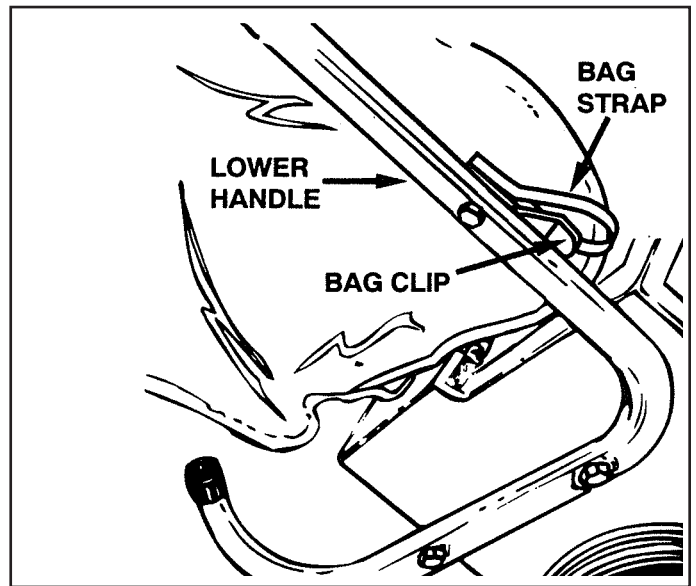

FIGURE 9

OPERATION

Take care when operating your sweeper. Operating your sweeper according to these instructions will help prevent damage and prolong the life of your sweeper.

BRUSH HEIGHT ADJUSTMENT

To adjust your sweeper brushes to the best operating height, loosen the hand knob and slide the height adjustment tube down to raise or up to lower the brushes. Best adjustment is when brushes are set 1/2" down into the grass. Always mow grass to even height before sweeping. See figure 10.

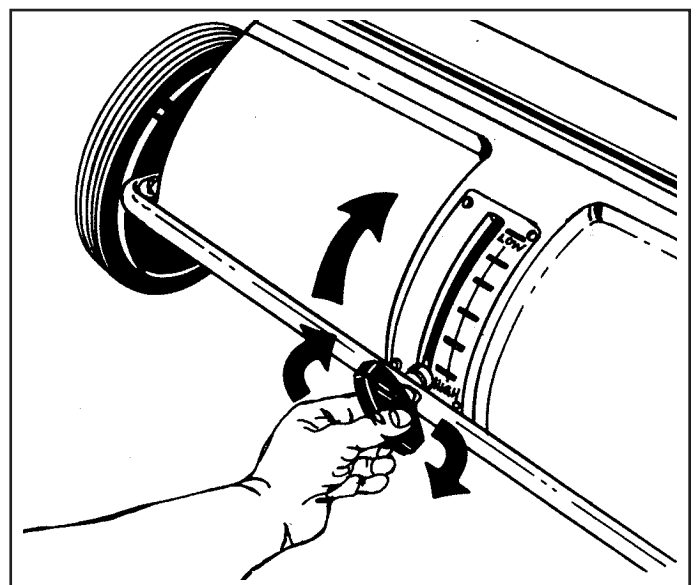

FIGURE 10



CAUTION: EYE PROTECTION SHOULD BE WORN WHILE OPERATING SWEEPER

DUMPING OF SWEEPER

To dump sweeper hopper bag, simply tip the sweeper forward or lift off the complete hopper bag frame.

Always dump hopper after each use. Damp or wet grass and leaves will cause damage to hopper if stored for long periods of time.



CAUTION: DO NOT DUMP THE SWEEPER TOO CLOSE TO A FIRE AS THE BRUSHES AND BAG CAN BE DESTROYED BY EXCESSIVE HEAT OR FLAME.

STORAGE

The entire unit may be hung on a wall or the hopper bag frame can be removed for storage.

LUBRICATION/MAINTENANCE

The bearings in the sweeper have been prelubricated at the factory. It is recommended that a few drops of light oil be added to the brush shaft bearings twice a year. The wheels should be removed to clean gears every two years. After cleaning, apply an even coat of light grease. See figures 11, 12 and 13.



NOTE:

To remove the wheel, pop off hub cap with a screw driver and remove retaining "E" ring and flat washer.

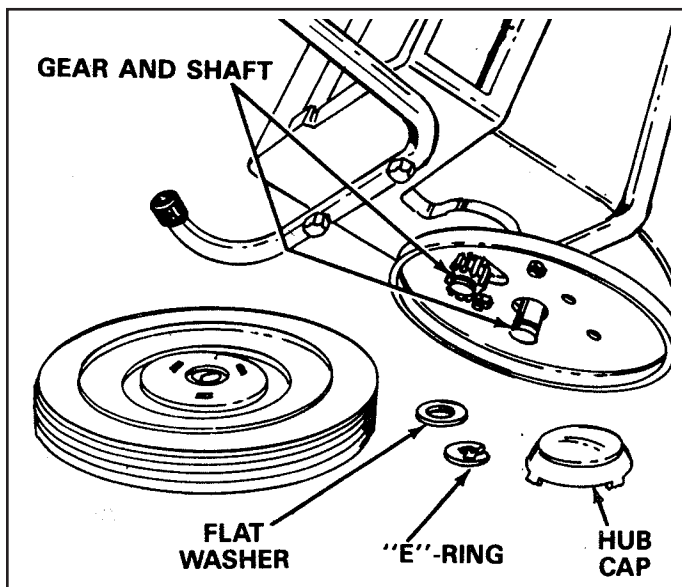

FIGURE 11

WHEEL GEARS/PAWL SERVICE

IMPORTANT: Do not remove both wheels at the same time to avoid mixing parts. (The R.H. and L.H. ratchet gears are not interchangeable.) Make notes on the position of washers and snap rings during disassembly.

1. Remove only one wheel from the sweeper.
2. Remove the retaining rings and washers which hold the ratchet gear onto the brush shaft.
3. Remove the gear by sliding it off the brush shaft. (Look for the drive pin, which may fall out of the brush shaft when the ratchet gear is removed.)
4. To reassemble, insert the drive pin through the hole near the end of the brush shaft. Make sure the pin slides back and forth easily in the shaft.
5. Lightly grease the shaft and fill the ratchet gear with grease. Assemble the ratchet gear back onto the shaft.
6. Lightly grease the axle and the gear teeth on the wheel and then reassemble the wheel. The brushes should rotate only during forward movement. If the brushes rotate by both forward and reverse movement, the drive pin is jamming in the ratchet gear. Dissamble, clean and lubricate the drive pin and ratchet gear and then reassemble wheel.
7. Remove opposite wheel and repeat steps 1-6 for that wheel.

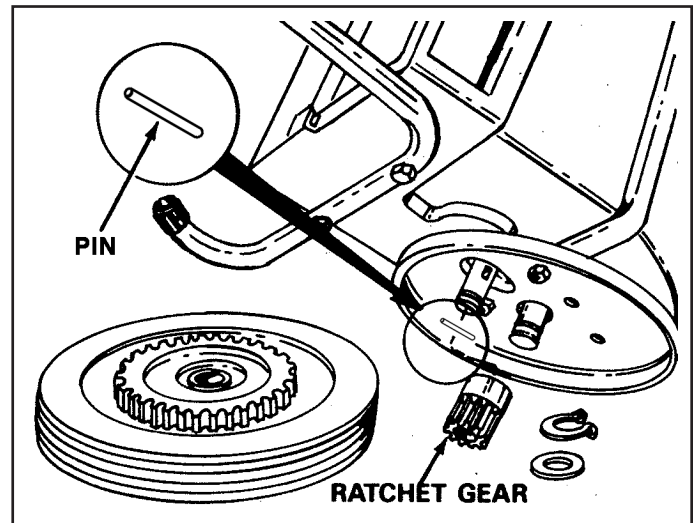

FIGURE 12

BRUSH REPLACEMENT

1. Remove the hopper bag from lawnsweeper.
2. Brush replacement should be done one brush at a time.
3. Tip the sweeper forward on housing for ease of brush replacement. Do not remove hex bolt from double brush retainers through brush shaft.
4. Loosen hex bolts and hex lock nuts from single brush retainers. See figure 13. Slide brush out of retainers, making note of over-lap bristles position.
5. Install new brush, making sure over-lap bristles are positioned the same as before and as shown in figure 13.

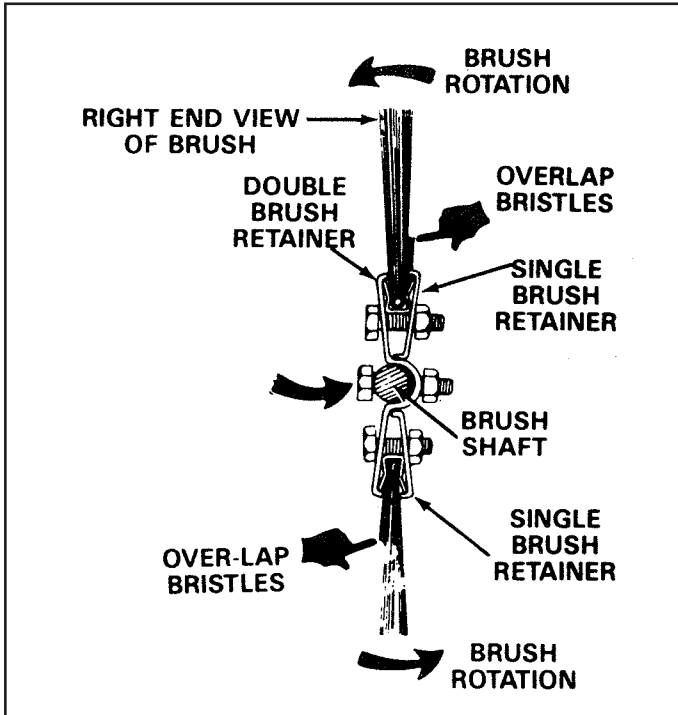

FIGURE 13

REPAIR PARTS FOR 45-02181 26" LEAF/LAWNSWEEPER

REF. NO.	PART NO.	QTY.	DESCRIPTION	REF. NO.	PART NO.	QTY.	DESCRIPTION
1	44600	1	Housing	28	44125	4	Flat Washer, .62 x 1"
2	23784	1	Height Adjustment Plate	29	44687	2	Plastic Cap, .207
3	44286	4	Bolt, Hex 10-32 x 5/8"	30	1650-21	4	Retaining Ring, .594
4	43681	1	Bolt, Carriage 5/16-18 x 1-1/2"	31	23782	1	Brush Shaft
5	44680	1	Washer, Nylon	32	43661	4	Bolt, Hex 1/4-20 x 1"
6	1543-69	1	Washer, Nylon 21/64	33	43013	8	Lock Nut, 1/4-20
7	44695	1	Washer, Bowed	34	44681	4	Brush, 13-1/4"
8	R19111116	1	Washer, 11/32 x 11/16	35	23580	4	Brush Retainer, Double Bracket
9	43720	1	Knob, 5/16"	36	23581	8	Brush Retainer, Single Clip
10	44946	1	Height Adjustment Tube	37	43012	8	Bolt, Hex 1/4" x 3/4"
11	23866	2	Dust Cover	38	44603	1	Upper Handle Tube
12	44598	2	Axle	39	44595	2	Handle Leg Tube
13	43070	4	Washer, 3/8"	40	44683	1	Bag Rod, 1/4" x 25-1/2"
14	44684	2	Jam Nut, 3/8-24	41	44682	1	Bag Rod, 1/4" x 28-1/2"
15	1038	2	Lock Nut, 3/8-24	42	726-0106	2	Palnut, 1/4"
16	44685	2	Shoulder Spacer	43	44688	2	Plastic Cap, 3/4"
17	40007	2	Washer, .596 x 1.125 x .025	44	44696	4	Bag, Rod Clip
18	716-0106	2	"E" Ring, 5/8"	45	43978	4	Bolt, Curved 1.4-20 x 1"
19	44679	2	Flange Bearing, .59	46	1509-90	4	Bolt, Hex 1/4-20 x 1-1/4"
20	49946	2	Wheel Assembly	47	43088	4	Washer, 1/4"
21	741-0249	4	Flange Bearing, .63	49	44694	1	Hopper Bag
22	44692	4	Bolt, Hex 5/16-18 x 1/2"	50	43662	4	Lock Nut, 10-32
23	43064	4	Lock Nut, 5/16-18	51	47189	12	Nylock Nut, 1/4-20
24	2674-32	2	Black Hub Cap		40261	1	Owner's Manual
25	48651	1	Pinion, L.H. 11 T.				
26	48652	1	Pinion, R.H. 11 T.				
27	47046	2	Pin, Drive				

SpeedPart *the fastest way to purchase parts* www.speedpart.com

NOTES

NOTES

SpeedEPart *the fastest way to purchase parts* www.speedepart.com

REPAIR PARTS

Agri-Fab, Inc.
303 West Raymond
Sullivan, IL. 61951
217-728-8388
www.agri-fab.com

This document (or manual) is protected under the U.S. Copyright Laws and the copyright laws of foreign countries, pursuant to the Universal Copyright Convention and the Berne convention. No part of this document may be reproduced or transmitted in any form or by any means, electronic or mechanical, including photocopying or recording, or by any information storage or retrieval system, without the express written permission of Agri-Fab, Inc. Unauthorized uses and/or reproductions of this manual will subject such unauthorized user to civil and criminal penalties as provided by the United States Copyright Laws.

© 1992 Agri-Fab, Inc.